

# Vacuum Tube Testers



Robert KM6RSS

# Agenda

- Introduction
- Tube Basic Anatomy
- Electron **Emission**
- Tube Types
  - **Diode**
  - **Triode**
  - Tetrode
  - Pentode
  - Multi-element
  - Phototube
  - Cathode Ray Tube (CRT)
  - Magnetron
  - Klystron
  - Traveling Wave Tube (TWT)
- “Good” Tube, “Bad” Tube
- Tube Failure Analysis
- Tube Tester Types
- Collecting Tube Testers (and parts)
- Summary
- Questions

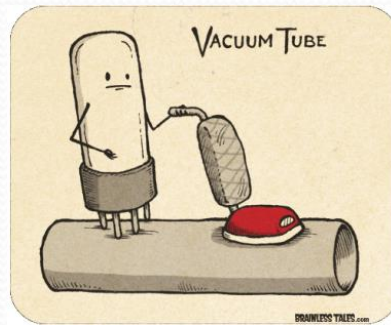

(Special thanks to S. Hudson, PE KI6BSQ)



# Introduction



- Vacuum tube developed in 1904 by John Ambrose Fleming
- By mid-20s tube radios were in high demand
- First home radios used a simple 4-pin vacuum tube
- Tubes were user-replaceable; how to determine if “good” or “bad” (problem could be other discrete components)
- Tube tester “styles”
  - Shop tester for use on the workbench
  - Portable tester for use by the repairman for house calls
  - Drug store tester for customers use to test and replace their own tubes



# Tube Basic Anatomy

- Main operating elements:
  - Filament
  - Cathode
  - Grid(s)
  - Plate
  - Getter
- US numbering: vLnC
  - v – one- or two-digit filament voltage
  - L - one or two letter sequence code
  - n – number of elements
  - C – special characteristics
  - Example: 12AX7A Dual Triode

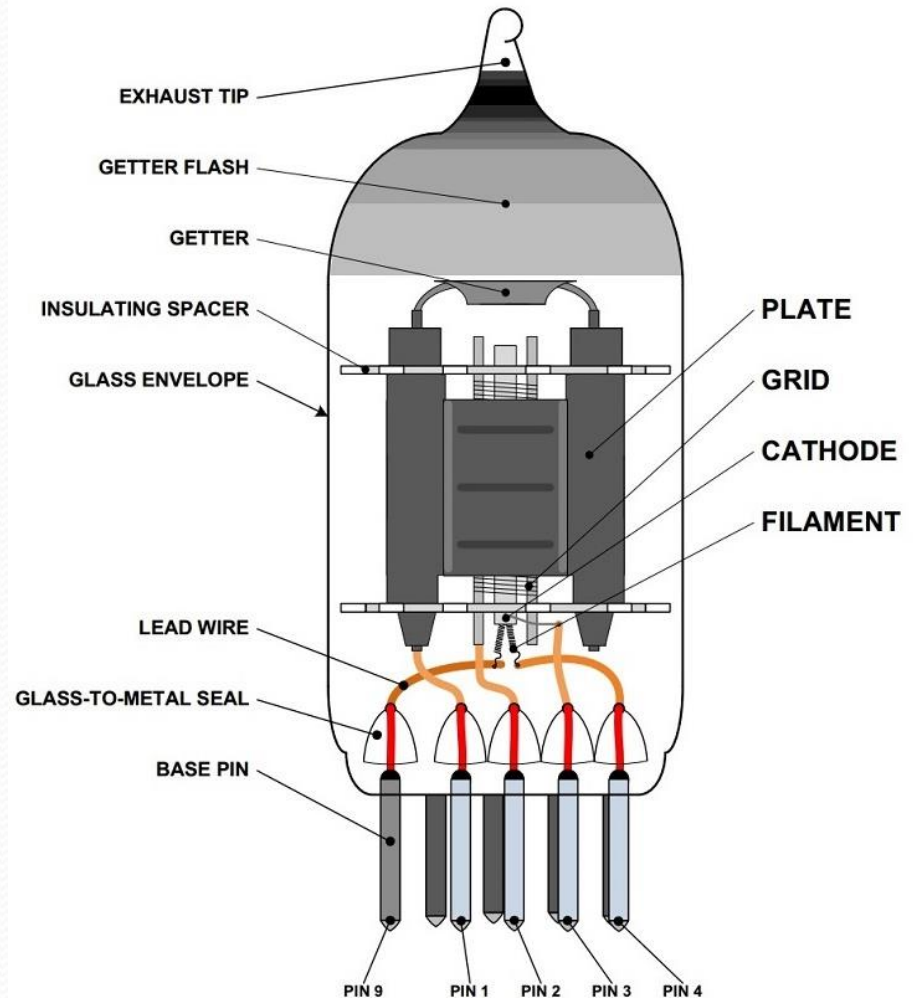

# Electron Emission

- Photoelectric – material emits electrons proportional to light intensity and wavelength(s)
- Secondary – electrons escape material when hit by electron of enough velocity/energy
- Cold-cathode (field emission): electrons pulled out of material by strong positive potential.
- **Thermionic** – heated material transfers energy to electrons causing them to escape. Number of electrons depends on temperature and type of material.

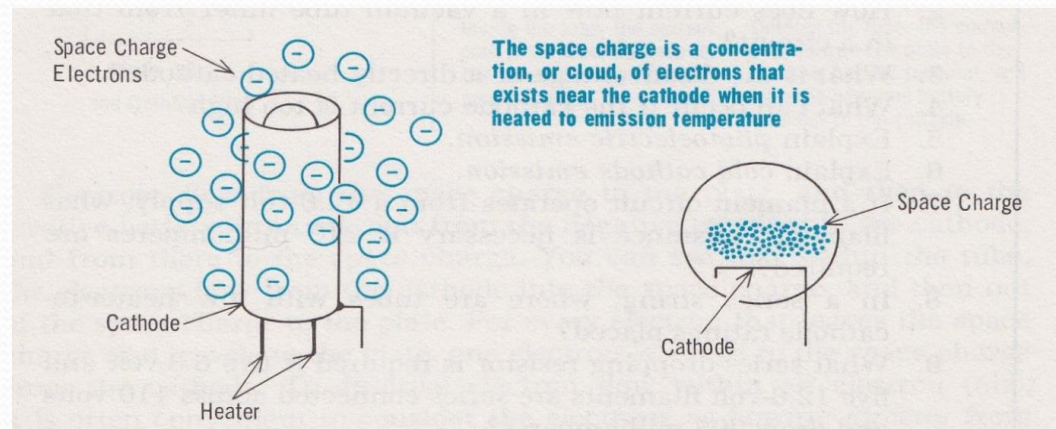

14000 Watt 892-R Transmitter Tube Heater 22 V 56 A

# Diode

- Two electrodes: cathode and plate
  - Plate constructed of nickel, molybdenum, or monel (nickel/copper alloy).
  - Continuous conduction with positive voltage connected @ plate and negative voltage connected at cathode.

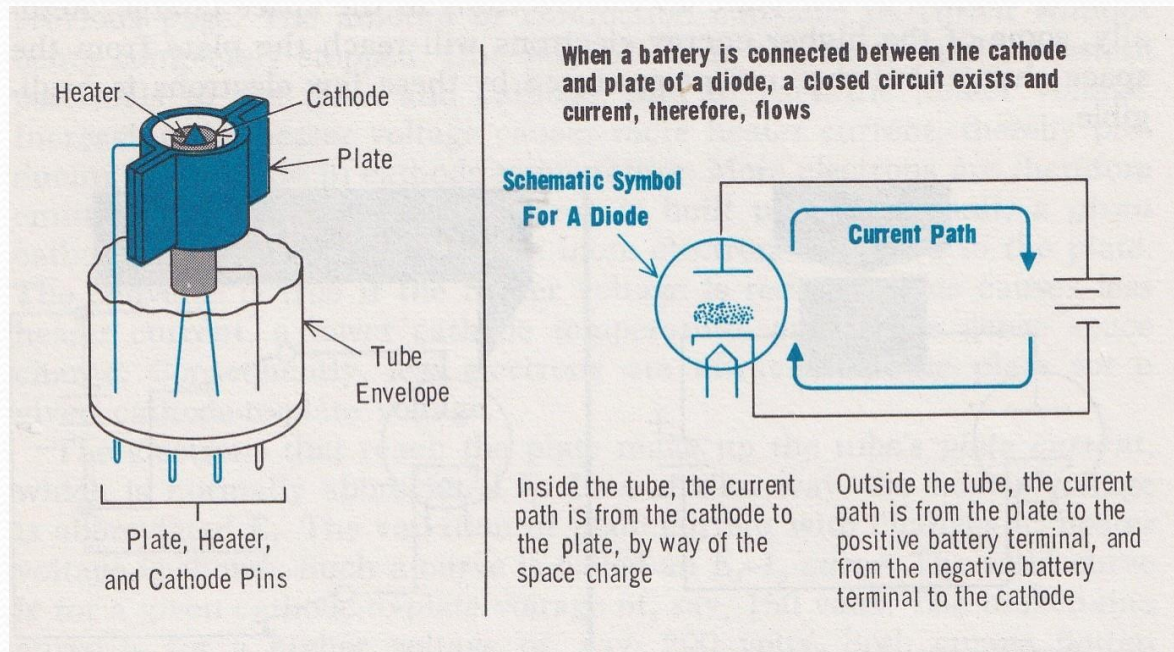

# Triode

- Third electrode, “control grid”, positioned between cathode and plate.
- Applying voltage between cathode and control grid controls cathode – to – plate electron flow.
- DC voltage or “bias” sets operating conditions on the characteristic curve.
- Provides means for tube to amplify signal voltage applied to grid.

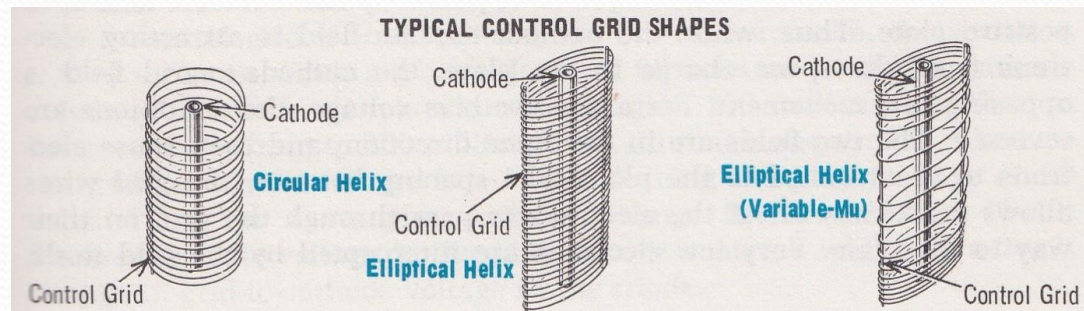
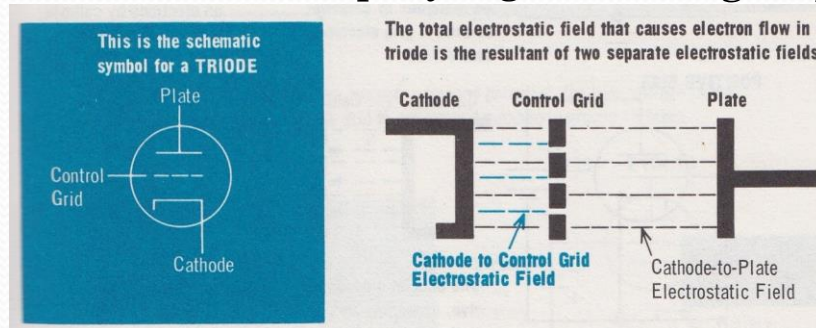

# Other Types of Tubes

- **Tetrode**
  - **Four active electrodes.** The four electrodes in order from the center are: a thermionic cathode, first and second grids, and a plate.
- **Pentode**
  - Similar to a tetrode with a **suppressor grid**
- **Multi-element**
  - Classified by the number of active electrodes they have, and each type of tube has different functions (e.g. Pentagrid converter: Also known as a heptode, this tube has seven elements and combines the functions of a signal mixer and an oscillator)
- **Phototube**
  - Photoelectric cell is a type of gas-filled or vacuum tube that is sensitive to light.
- **Cathode Ray Tube (CRT)**
  - Contains one or more electron guns, which emit electron beams that are manipulated to display images on a phosphorescent screen
- **Magnetron**
  - Used in early radar systems and subsequently in microwave ovens and in linear particle accelerators
- **Klystron**
  - Electron beam interacts with radio waves as it passes through resonant cavities, (metal boxes) along the length of a tube. The power gain of klystrons can be high, up to 60 dB (an increase in signal power of a factor of one million), with output power up to tens of megawatts, but the bandwidth is narrow.
- **Traveling Wave Tube (TWT)**
  - Elongated vacuum tube with an electron gun (a heated cathode that emits electrons) at one end. A voltage applied across the cathode and anode accelerates the electrons towards the far end of the tube, and an external magnetic field around the tube focuses the electrons into a beam. At the other end of the tube the electrons strike the "collector", which returns them to the circuit.



# “Good” Tube “Bad” Tube

- What makes a tube bad or good? Depends on usage:
  1. What is the application (guitar or audiophile amplifier, AM/FM radio, transceiver, linear amplifier, VTVM, etc.)?
    - a) Is the tube part of a pair or group (e.g. push-pull amplifier)?
  2. What are the limits on tube parameters?
    1. Grid voltage ( $V_G$ ), anode(plate) voltage ( $V_A$ ), plate current ( $I_A$ )?
    2.  $G_m$  (mutual conductance measured in micromho;  $\Delta I_A / \Delta V_G$ ),  $\mu$  (voltage amplification factor), dynamic resistance( $r$ )= $\Delta V / \Delta I$
    3. Low  $G_m$ =Low emission



# Tube Failure Analysis

TUNGSTEN-GLASS — SOME MATERIALS USED IN RADIO TUBES: — SILICON - ZINC  
-CALCIUM ALUMINUM FLUORIDE - RESIN (SYNTHETICI) - ETHYL ALCOHOL - PORCELAIN - POTASSIUM CARBONATE - BAKELITE

## Why Tubes should be tested every six months

**TINY WIRES WARP IN TIME** (11)

**HEAT INJURES INSULATION** (12)

**TEMPERATURE AFFECTS SEAL** (13)

**VACUUM DECLINES WITH AGE** (14)

**ELEMENTS RELEASE GASES** (15)

**CATHODE COATING BURNS OFF** (16)

**WELDED JOINTS ARE STRAINED** (17)

**VIBRATION UPSETS BALANCE** (18)

1 Grid wires are sometimes much smaller than a human hair  
2 Some insulation operates at incandescant heat  
3 Glass and wire must expand equally when heated  
4 Inside air pressure is 1/100,000,000th that of outside  
5 Power output tubes operate at several hundred degrees  
6 Variation in cathode coating less than 0.00007 ounce  
7 Constant expansion and contraction with temperature  
8 Construction still delicate despite best possible design

**RADIO and Television RETAILING**

**See Your Dealer Twice a Year**

MARBLE DUST - WOOD FIBER - STRONTIUM NITRATE - LEAD OXIDE - ZINC OXIDE - LAVA - MICA - TIN - SODIUM CARBONATE - SODIUM NITRATE - LEAD ACETATE - MALACHITE GREEN - GLYCERINE - ZINC CHLORIDE - IRON SILVER OXIDE -

- Tubes fail for three basic reasons:
  1. Age
    - a) Thoriated or zirconium dioxide filaments
    - b) Cathode coating (barium, strontium and/or calcium oxide, etc.)
  2. Shorts
    - a) Migration of metal, mechanical impact to tube, PS failures
  3. Gassy
    - a) Present as residual gases, entering the tube via leaks, or released by outgassing or migration from the construction elements

# Tube Failure Analysis cont.

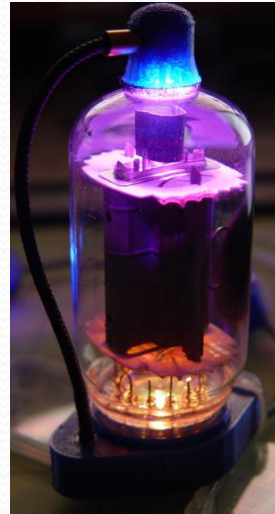
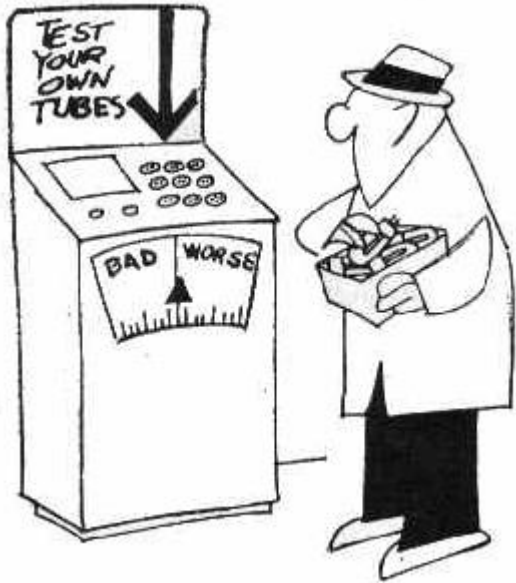

- Age examples
  - Cathode and/or filament has reached EOL
  - Red plating has occurred where grid bias has gone positive
  - Getter color will change to pure white

# Tube Failure Analysis cont.

- Substitution (if you have the tubes on hand)



# Tube Failure Analysis cont.



- Continuity of filament
- Shorts (and arcs)
  - Simplest Test (other than touching the tube for temp.)
- Can be done with a neon lamp circuit, DVM, etc.
- Limited value

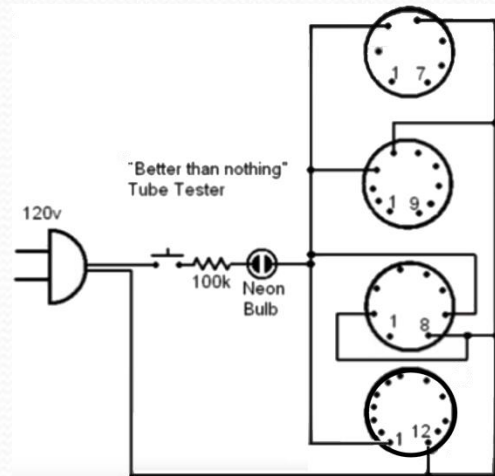

# Tube Failure Analysis cont.



Filament and cathode to suppressor grid (in pentodes) can be internally shorted

- Short Circuit Test
  - Identify if there are any shorts between the different pairs of pins



# Tube Failure Analysis cont.



## • Gas Test

- Some testers have a button to test for vacuum quality
- Gas causes the grid to become conductive
- Presence of gas results in actually changing the grid bias, which can lead to arcing
- Getter color

# Tube Tester Types

- Tube Checkers
  - Simple to use
  - Tube list gives appropriate socket number which has correct filament voltage, AC voltage load and meter shunt to receive “English” values (Bad, ? and Good)



# Tube Tester Types cont.

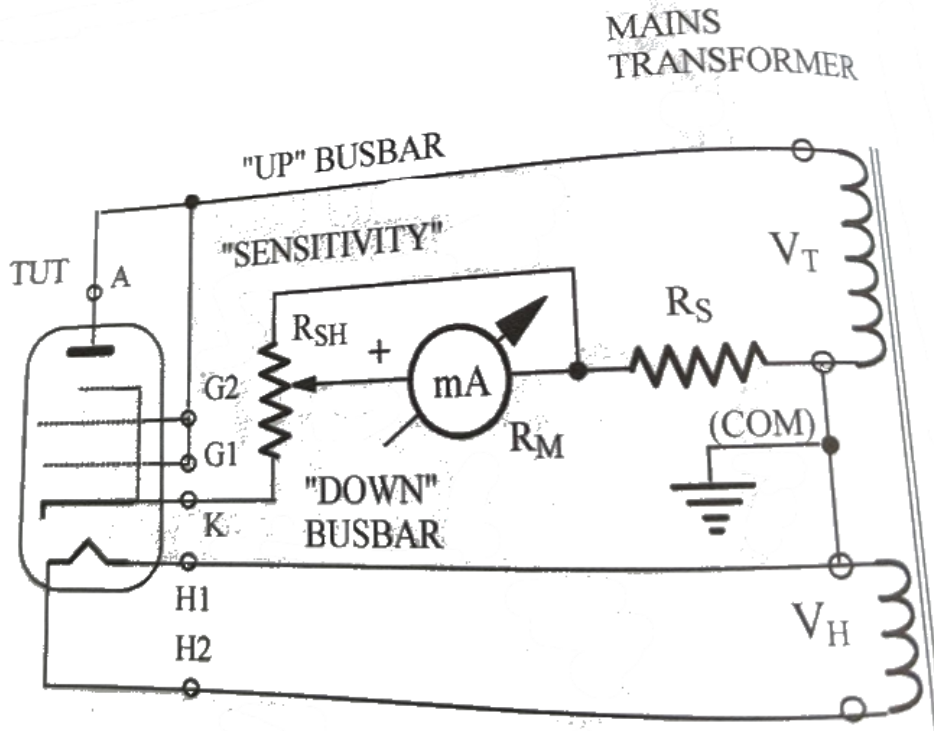

ABOVE: A typical emission test circuit

- Emission Testers
  - Tests tube as a diode; cathode to ground, grids and plate to low AC voltage. Need correct heater voltage and series metering (with shunt) of either cathode or plate and a datasheet

# Tube Tester Types cont.

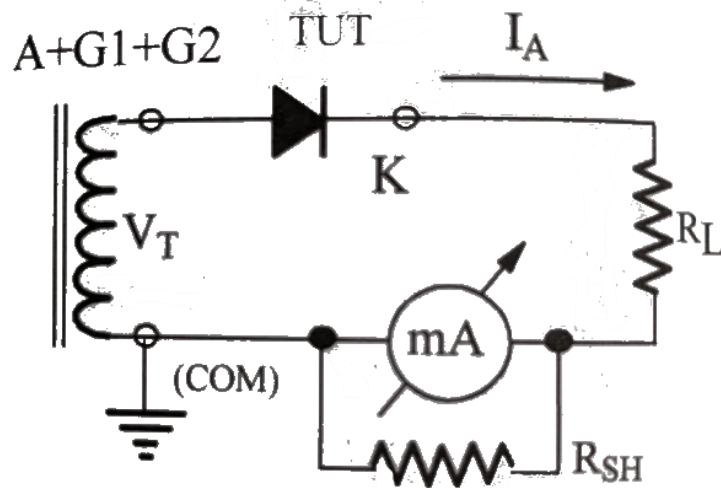

ABOVE: The simplified test circuit.  $R_L$  is the total load, meter's internal resistance  $R_M$ , plus the series resistor  $R_S$  and the lower part of the "Shunt" or "Sensitivity" rheostat.

- Emission Testers cont.
  - > emissive capacity of cathode, > current to closest electrode; control grid  $G_1$
  - Since  $G_1$  composed of thin wire, some testers connect  $G_1$  to cathode and use  $G_2$

# Tube Tester Types cont.

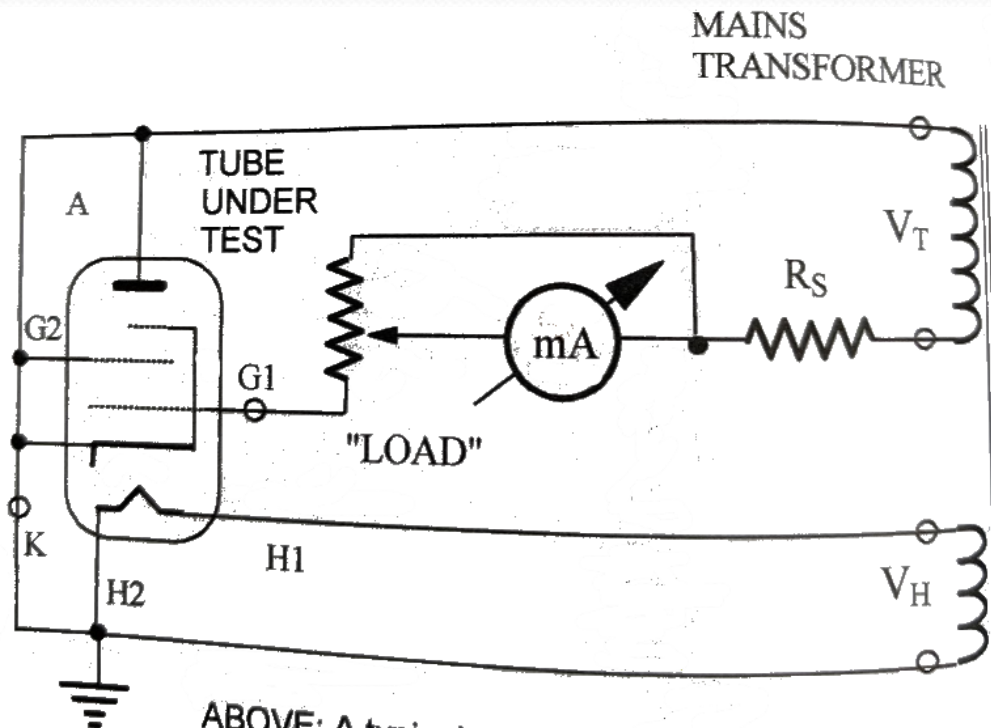

ABOVE: A typical grid circuit test arrangement.

- Grid Circuit Testers
  - Sub-category of emission tester
  - Connect plate and screen grid (G2) to cathode
  - Cathode emits electrons and control grid (G1) collects them
  - Only cathode and control grid tested!

# Tube Tester Types cont.

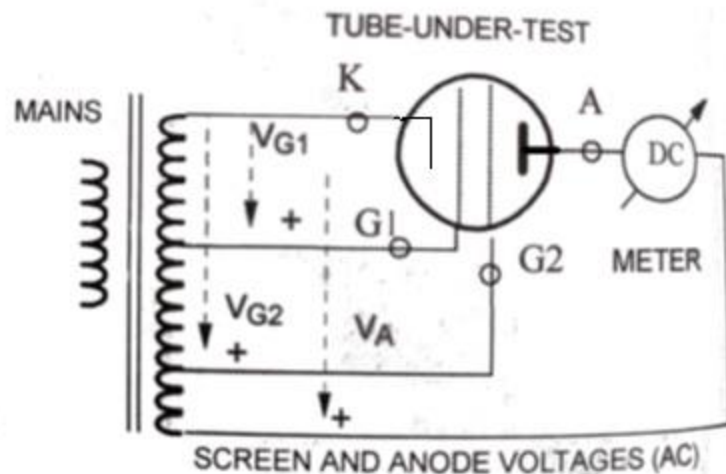

ABOVE: The operating principle behind dynamic conductance testers

- Dynamic Conductance Testers
  - Three electrodes ( $G_1$ ,  $G_2$  & plate) connected to AC
  - Tube acts as a rectifier & amplifier
  - Tests for cathode emission & effect of  $G_1$  to plate current

# Tube Tester Types cont.

- Dynamic Conductance Testers cont.

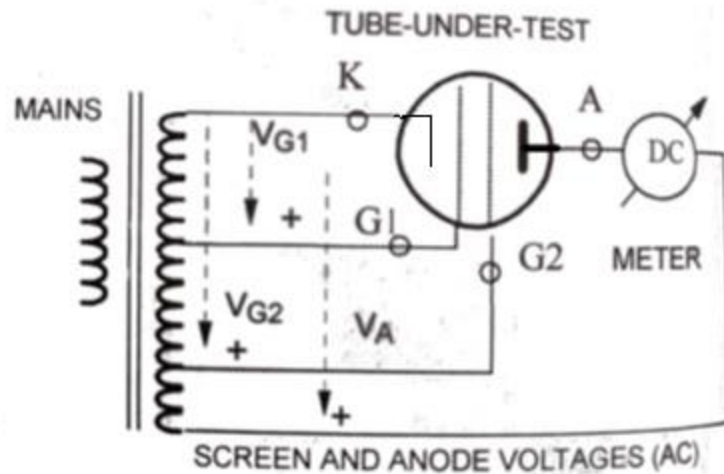

ABOVE: The operating principle behind dynamic conductance testers

- All 3 AC voltages are in phase
- $V_{G1}$  biases tube positively
- Testers use lower AC voltages to avoid high plate current

# Tube Tester Types cont.

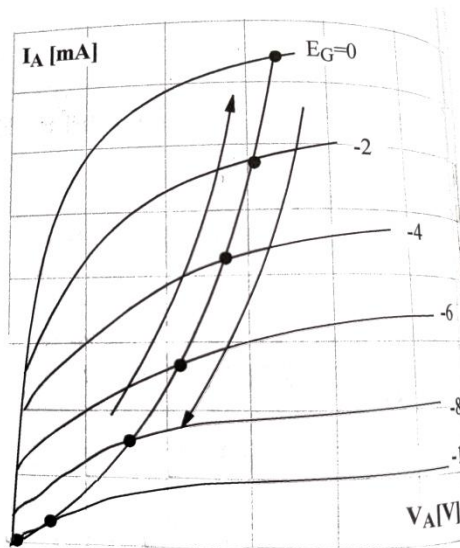

ABOVE: The illustration by Precision Apparatus Company of the "electronic" sweep of a power pentode.

- Dynamic Conductance Testers cont.
  - PACO shows operating point path moving through negatively biased pentode
  - Swing is actually above  $E_G = 0$  curve
  - FTC complaint



# Tube Tester Types cont.

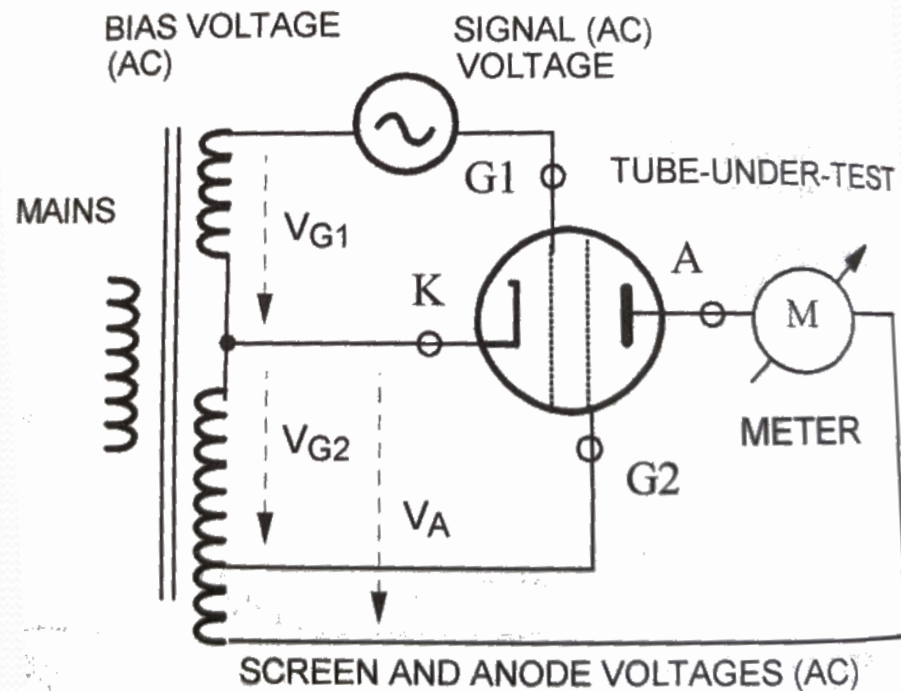

- Proportional Mutual Conductance Testers
  - Like a dynamic plate conductance tester
  - AC Bias voltage is out of phase with secondary voltages; tube is negatively biased
  - Lower than “real” tube voltages; anode > screen > bias, “in proportion”

# Tube Tester Types cont.

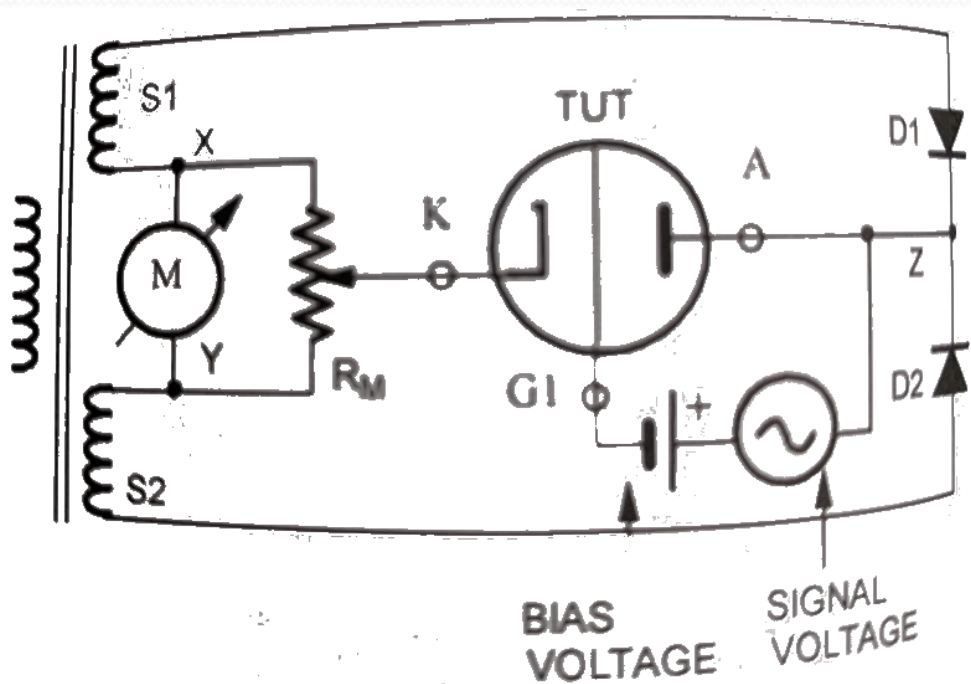

ABOVE: The Hickok bridge in principle

- Hickok Bridge Type “Transconductance” Testers
  - Bridge circuit patented in 1935
  - With only DC bias on  $G_1$  & no AC  $G_1$  signal, like a resistor
  - Every half-cycle of mains voltage, current direction through meter changes; meter stays static

# Tube Tester Types cont.

- Hickok Bridge Type Transconductance Testers cont.

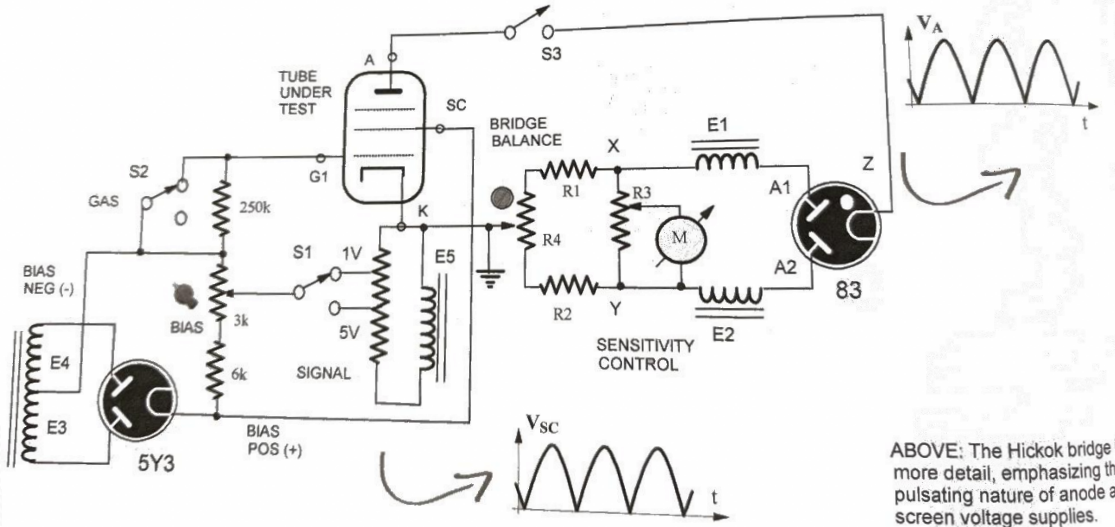

ABOVE: The Hickok bridge in more detail, emphasizing the pulsating nature of anode and screen voltage supplies.

- When G1 AC signal present, G1 voltage more positive during on half-cycle (tube conducts, internal R drops and meter current increases) and more negative during other half-cycle (tube conducts less current, internal R increases and meter current decreases)
- Net current > 0 and shows “relative”  $G_m$
- Analog meter needle inertia “trick”

# Tube Tester Types cont.

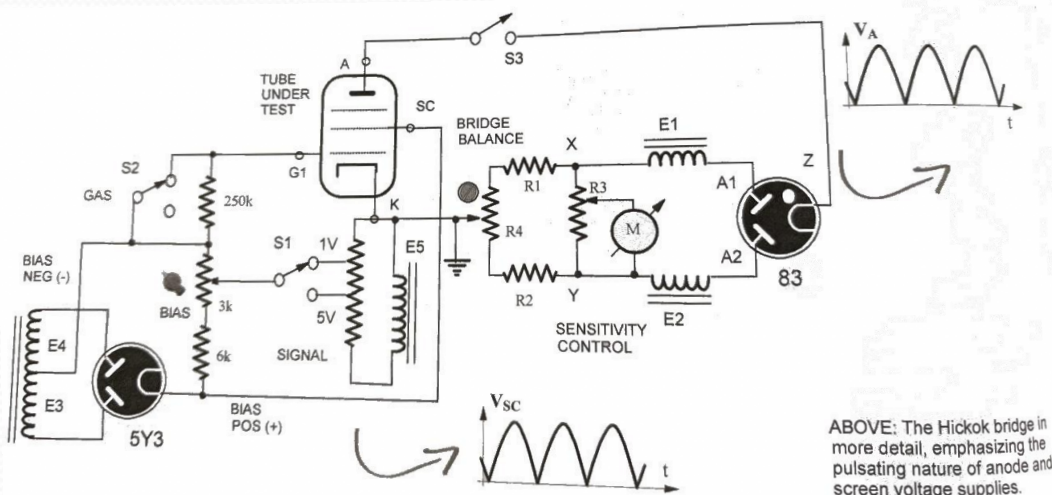

## • Hickok Bridge Type Transconductance Testers cont.

### • Issues

- Two (bridge) transformer windings must be equal
- Only one pair secondary windings gives single plate voltage (150-170 V)
- No regulation or stabilization; dependent on stable mains voltage of 50-60 Hz and possible hum
- G<sub>1</sub> AC signal (5 V, very high!) is scaled down from AC mains, leakage between heater & cathode (or other electrode) introduces hum and changes +/- actual G<sub>m</sub>



# Tube Tester Types cont.



- Hickok Bridge Type Transconductance Testers cont.

- Issues cont.

- Difficult to test dual tubes
    - Bias pot not linear
    - Rating using " $G_m$ " of older testers based on bogey values; newer ones based on "lowest acceptable limits" set by?
    - Cathode connected to wiper of bias pot, as grid bias  $>$ , screen-to-cathode voltage  $<$  by same

# Tube Tester Types cont.

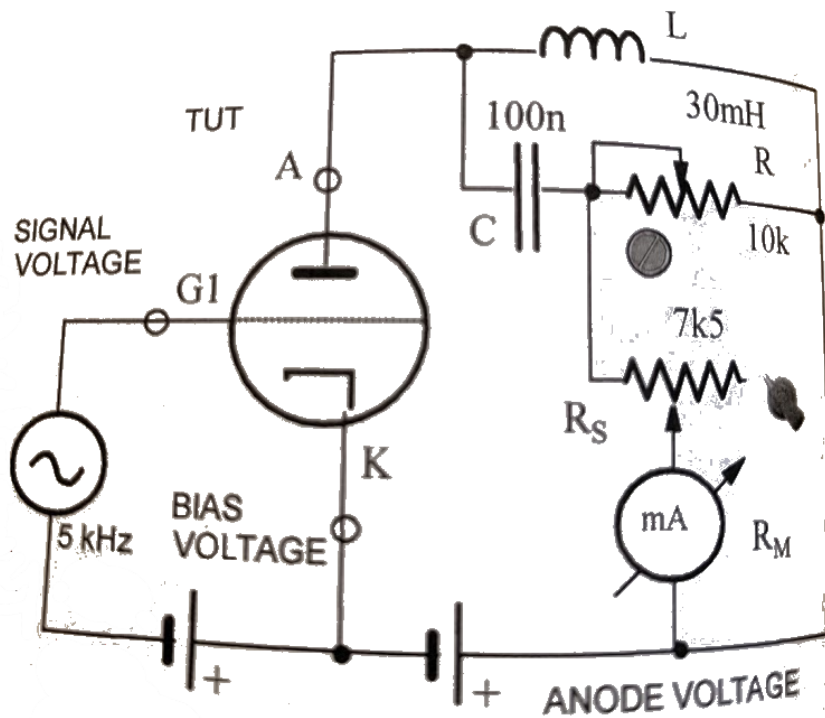

ABOVE: The G<sub>m</sub> test circuit of Heathkit TT-1

- True Mutual Conductance Testers
  - Use DC plate, screen and bias supplies
  - Many aren't stabilized but few commercial testers are (Kalibr L3-3)
  - Many have too low a plate voltage to compare to actual "in circuit" testing

# Tube Tester Types cont.



- True Mutual Conductance Testers cont.
  - Does what the previous testers do and uses ac and dc voltages to measure the amplification
  - One of the valuable tube testers in today's market manufactured for service and for use by the military in the late 1950s and 1960s. Will test a wide range of audio tubes. The resurgence of the tube audio market has driven prices up on many of these later models



# Tube Tester Types cont.



- Card-Pin (switchboard) Testing Types
  - A tester of this type (Funke W20, Kalibr L3-3) applies DC voltage (and filtered 1.4kHz AC) to the tube being tested and datasheet values are verified under real conditions.
  - Some parametric testers apply AC voltage to the tube being tested, with verification under conditions which simulate DC operation.

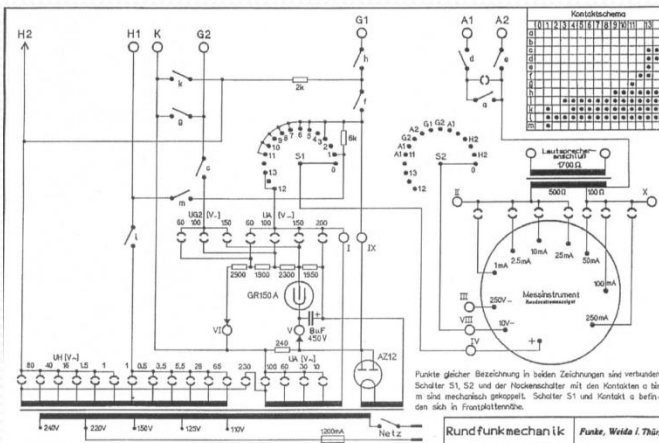

# Tube Tester Types cont.

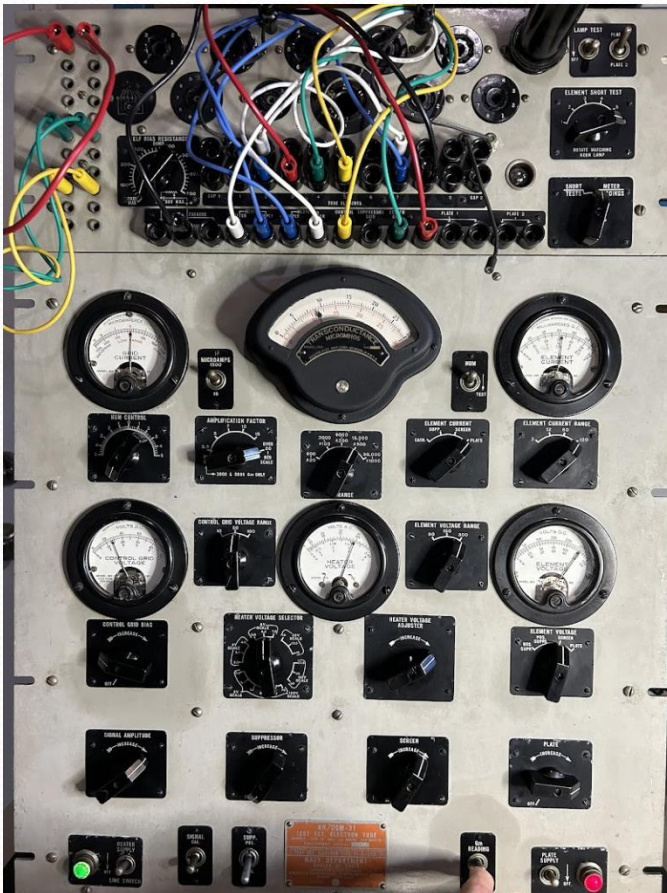

- Patch Cable Connector (switchboard) Testing Types
  - Weston 686 Parametric Vacuum Tube Tester

## WESTON 686 TYPE 10A

S/N 1521 shown\*

The Weston 686 is a direct Gm reading tube analyzer. It was preceded by the Type 9 and a variety of others, and was produced as a military type for the US Navy, as the OD version. There were several earlier military versions as well.

Gm is read directly on the fan shaped meter without any calculations needed. The meter has 8 effective full scale Gm readings of 300, 600, 1,500, 3,000 and x10 ranges of 3,000, 6,000, 15,000, and 30,000 micromohs.

This industrial tube analyzer used 60Hz signal for the grid circuit and a handful of separate filtered and monitored DC power supplies for various element voltages, which were read on the switched meters. It also featured both low and high power grid settings, and a variety of other enhancements to evaluate virtually all of the tubes of the day.

# Tube Tester Types cont.



Hickok Cardmatic Model AN/USM-118B

- Card reader types
  - Less mistakes than having to turn multiple switches to set filament,  $G_1$  bias, signal, multi-grid and anode voltage, etc.

# Tube Tester Types cont.



- Modern Digital (non-vacuum tube-based)
- A microcomputer PIC clocked at 12 MHz carries out the acquisition, measurement and management of defects
- A semiconductor curve tracer can be connected to a tube tester and an oscilloscope for curve tracing
- Must use tube book and patch cables

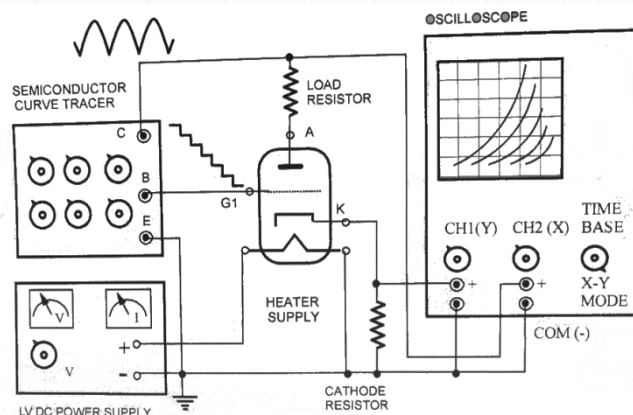

ABOVE: Test setup for displaying triode's anode (plate) characteristics on an oscilloscope. AC heating voltage can be used instead of the DC power supply.

# Tube Tester Types cont.



- Modern Digital cont.
  - Manual (patch) wiring to tubes
  - Automatic but some limited to few tube types
  - PC needed with some



# Tube Tester Types cont.

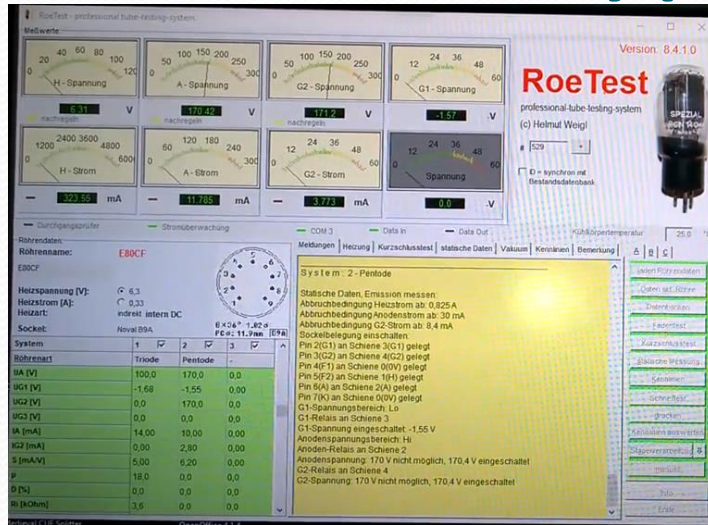

- Modern Digital cont.
  - Computer-connected
  - Roe Test from Germany
  - Ordered custom parts August 2023, arrived October, ordered “remaining” parts from Reichelt (Germany); all but four (not in stock) arrived November
  - Continued to order more parts on a monthly basis (Mouser, Digikey)
  - Started testing and adjusting it in September 2024. Dave (AI6VX did SMD soldering and “correction” repairs)



# Tube Tester Types cont.



- Hybrid testers
  - Some popular card-based testers (Cardmatic Tube Tester AN/USM-118B) can be modified for automated testing
  - Computerized testers



# Tube Tester Types cont.



- “Cobbled together” testing
  - Can measure detailed information on all operating parameters
  - Requires expertise and caution
    - **Danger, high voltage**

# Collecting Tube Testers (and parts)



HICKOK 539C TUBE TESTER FAIR CONDITION WORKING 100%

Pre-Owned

★★★★★ 3 product ratings

**\$1,799.00**

or Best Offer

Free Shipping

Free Returns

57 Watching

2 pre-owned from \$1,799.00

Top Rated Plus



Hagerman VacuTrace Tube Tester & Curve Tracer - REDUCED 20%!

Pre-Owned

**\$1,599.00**

or Best Offer

Free Shipping

16 Watching



TV-3B/U TUBE TESTER BY HICKOK ELECTRICAL INSTRUMENT COMPANY

New other (see details)

**\$1,200.00**

or Best Offer

+\$400.00 shipping

1 new & refurbished from \$1,200.00

From Pakistan



Test Set Electron TV-7A/Utube tester

Pre-Owned

**\$935.00**

Buy It Now

+\$50.00 shipping

- Prepare to spend time and \$
- Some “works fine” means I don’t really know if it works
- Base prices vary; look at shipping cost\$

# Collecting Tube Testers (and parts cont.)



- My collection (partial)
  - DynaMatic DM 456 \$36
  - (2) Heathkit TT-1 \$250 ea
  - (2) RCA WT-110A \$170 ea
  - Hickok 533DM, 534, 539B, 1230 \$300
  - DuoVac \$350
  - Precision Apparatus Series 912 Electronic Tube Tester \$69
  - Kalibr L3-3 \$700
  - Roe Test V11 \$\$\$

# Collecting Tube Testers (and parts cont.)



- Electronicon high voltage capacitor 10 uf 680VDC \$50
- Microwave Oven High-Voltage Capacitor 1.0UF \$20
- 2uF 1000V Oil Hermetically Sealed Capacitor \$15
- Selectable 14 Voltage AC Power Supply Has EICO Tube Tester Filament Transformer \$45

# Collecting Tube Testers (and parts cont.)



- High Voltage Power Supply PDI Model 1570 0-3 kilovolt, 0-40 ma Positive & Negative \$100
- High Voltage DC-DC Boost Converter 5V-12V Step up to 300V-1200V Power Module \$10
- DC Power Supply High Voltage. \*\* Variable \*\* 0-1KVdc, Lot of 2 \$25

# Collecting Tube Testers (and parts cont.)



Unfortunately, it doesn't work; bad assembly by the original builder

- Heathkit IT-1121 Semiconductor Curve Tracer \$120
  - 9 voltage steps, 1 V max
  - 200 V sweep @ 200mA
  - Horizontal sensitivity 100mV to 50 V/div
  - Vertical sensitivity (4) ranges from 0.5 V/div to 200 V/div

# Collecting Tube Testers (and parts cont.)



- Tektronix 577 Curve Tracer with 177 (transistors) and 178 (op amps) test fixtures (\$550 cost with 177 test fixture, \$360 for 178 plus ~ 10 small fixtures @ \$50 avg. each (needs repair))
- HealthKit-Zenith SP2717 Vacuum Tube Power Supply \$150

# Summary



- Enjoyable if you like getting dirty, cleaning dust bunnies and mold out of chassis and cases (spider webs and carcasses, too)
- Fun to hunt down schematics and instruction books when testers don't work; especially foreign language ones
- Strange desire to buy old tubes just to “test your testers”
- Takes up a lot of space and tubes (and testers) are fragile
- If you are into vintage radios and equipment, a must have to test the tubes. Most capacitors have gone bad so don't test the device at full power; use a variac and isolation transformer
- Credits: Slide diagrams 12-23 Popovich, Igor “How to Use, Calibrate, Repair and Upgrade Vacuum Tube Testers” ISBN 978-0-9806223-7-9, pub. Career Professionals in Australia, 2017, Photos for slides 1-37 eBay.com sellers, Cartoons <https://jacmusic.com/Tube-testers/>, <http://tone-lizard.com/tube-testers/>, [https://robobinette.com/Ham\\_VHF-UHF\\_Digital\\_Modes.htm](https://robobinette.com/Ham_VHF-UHF_Digital_Modes.htm), [https://www.cartoonstock.com/directory/v/vacuum\\_tube.asp](https://www.cartoonstock.com/directory/v/vacuum_tube.asp), etc.
- FAIR-USE COPYRIGHT DISCLAIMER: \* Copyright Disclaimer under section 107 of the Copyright Act 1976, allowance is made for “fair use” for purposes such as criticism, comment, news reporting, teaching, scholarship, education and research.



# Questions?



"YOU SEE, DR. BUCKLEY, IT DOES MAKE A DIFFERENCE. YESTERDAY ON THE SOLID-STATE LIFE-SUPPORT MACHINE HE WAS RESTLESS, IRRITABLE. TODAY ON THE VACUUM-TUBE MACHINE HE'S CONTENT, SERENE..."